

CALYPSO SERIES

HEIGHT ADJUSTABLE ELECTRIC BASES

Designed to move with you!



**2 LEG
& 3 LEG
MODELS**

15
STRUCTURAL
WARRANTY
YEAR

7
MECHANICAL
WARRANTY
YEAR

THE
IN-STOCK
ADVANTAGE

ECO STORY

Features

- Quick Assembly - Fold-out leg frame
- Extended Height Range: 22" - 48" (excludes 1" top)
- Heavy duty 3-stage steel frame
- 4 programmable memory positions
- Actuator system with synchronized motor driving each leg
- Flexibility - designed to work with the **NEW** Innovations tops (sold separately) or RETRO FIT your existing top to this unit
- Contemporary offset foot leaves room for keyboard tray or other accessories
- Product is **IN-STOCK**

Base Finishes



Width Adjustment:

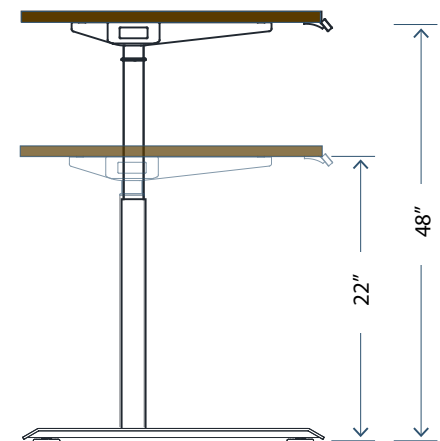
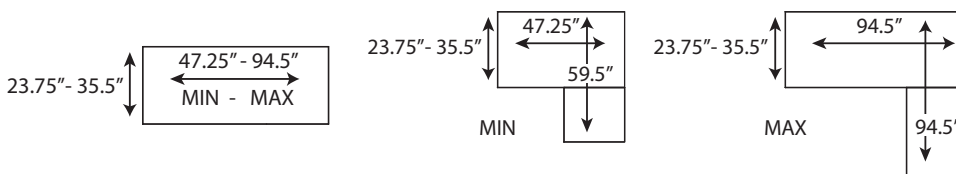

Model:
CAL-E1-2LEG
CAL-E1-3LEG

Description:
Straight Desk
L Shape Desk



Technical Specifications:

- Anti-collision function - stops automatically if it hits an immovable object
- Actuator system with synchronized motor driving each leg
- Operated at 1.3" per second
- Whisper quiet <50dB
- Lifting Capacity: 2-LEG - 265lbs
3-LEG - 320lbs
- CSA/UL Certified
- BIFMA Certified

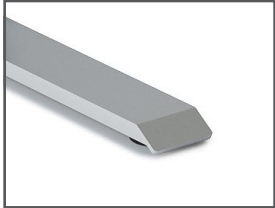

Adjustable glides for easy leveling on uneven surfaces



Easy to use key pad with 4 programmable memory positions



Accessory: Wire Management 100-WM1300

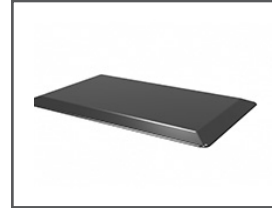

Accessory: Anti-fatigue Mat 100-2030AFM



Accessory: Hanging CPU holder 100-2-HPCU

Innovations Laminate Tops

Model:

INV-2436TOP (Return Only)
 INV-2442TOP
 INV-2448TOP
 INV-3060TOP
 INV-3066TOP
 INV-3072TOP
 INV-362466ECM
 INV-362471ECM

Description:

35.5"W x 23.75"D x 1"H
 41.5"W x 23.75D x 1"H
 47.25"W x 23.75D x 1"H
 59.25"W x 29.5"D x 1"H
 65"W x 29.5"D x 1"H
 71"W x 29.5"D x 1"H
 65"W x 35.5/23.75"D x 1"H
 71"W x 35.5/23.75"D x 1"H

Optional Caster

900-CASTER-M8-MB

- Sold quantity 2 casters
2 leg base - 2 set required
3 leg base - 3 sets required
- Durable PVC material
- Safe for use on soft or hard floors
- M8 threaded stem caster
- Maximum weight 32kg/66lbs per caster



Examples:

INV-2448TOP + CAL-E1-2LEG	INV-3060TOP + CAL-E1-2LEG	INV-3066TOP + CAL-E1-2LEG	INV-3072TOP + CAL-E1-2LEG	INV-362466ECM + CAL-E1-2LEG + CAL-E1-2LEG-CMF	INV-362472ECM + CAL-E1-2LEG + CAL-E1-2LEG-CMF	INV-3060TOP INV-2436TOP INV-2442TOP or INV-2448TOP + CAL-E1-3LEG	INV-3066TOP INV-2436TOP INV-2442TOP or INV-2448TOP + CAL-E1-3LEG	INV-3072TOP INV-2436TOP INV-2442TOP or INV-2448TOP + CAL-E1-3LEG
------------------------------	------------------------------	------------------------------	------------------------------	---	---	---	---	---

Laminate Top Finishes:

Autumn Maple (AM)	Evening Zen (EZ)	Grey (GR)	Grey Dusk (GD)	Hardrock Maple (HM)	Pure White (PW)	Royal Mahogany (RM)	Sugar Maple (SM)	Winter Wood (WW)



Heartwood Distributors Ltd.

Choose high quality, price sensitive products that are **IN-STOCK** and ready for next day shipping.
www.heartwooddl.com

Contact your local dealer:

251 Adams Rd, Kelowna, BC V1X 7R1
 T: 1 800 567 3060
 F: 250 765 1213